

TenPoint Crossbow Technologies™

STEALTH XLT™ ASSEMBLY INSTRUCTIONS

To prevent injury to yourself or others, or damage to your crossbow, read this manual along with all other operating and safety instructions included in your crossbow package before assembling, loading or using the crossbow.



THIS MANUAL COVERS:

STEALTH XLT™

STEALTH XLT (XTREME LIMB TECHNOLOGY) ASSEMBLY

The XLT style crossbows are easy to assemble. Basically, you only have to bolt the bow assembly to the stock assembly, install the foot stirrup and you are ready to shoot. Once assembled correctly, your crossbow is pre-sighted for 20-yards.

Lay out the contents of your XLT crossbow box in front of you. Be certain the box contains all of the following items before beginning assembly (photo 1):

- One (1) complete stock assembly
- One (1) complete bow assembly
- One (1) cable saver
- One (1) VIBRA-CUSH™ (pre-installed at factory)
- One (1) large clear plastic bag containing paperwork (including a warranty card) and one (1) other sealed plastic bag containing the main assembly bolt, Allen wrenches and a sample tube of oil.

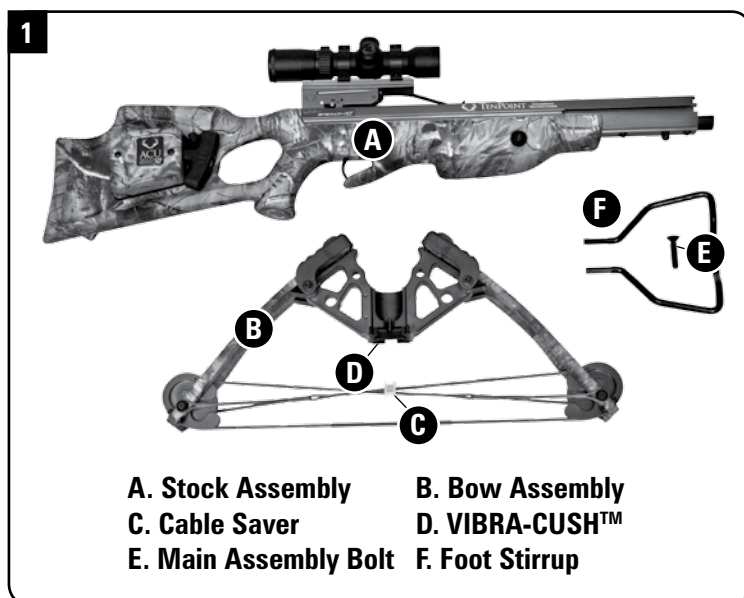

ASSEMBLY STEPS

1. Attach the cable saver to the cables. **Note: Do not attach the bow assembly to the stock assembly without the cable saver – cable damage will occur and the crossbow will be unsafe to shoot.**

- When viewing the cable saver from the side, with its “dish” (concave surface) facing up, notice that one of the two cable notches is positioned deeper into the cable saver (closer to the “dish”) than the other.

- Because the cables cross, one rests on top of the other. The top cable goes into the deeper of the two cable saver notches and the bottom cable goes into the shallower cable saver notch (photo 2), allowing the cable saver to maintain a relatively level position on top of the two cables.

- Before sliding the cable saver into the barrel’s cable slot, apply a drop of Flight Groove / Trigger Lube (HCA-111) or MicroLon’s® Precision Oiler (HCA-11107) to the “dish” (concave surface) or top of the cable saver (the part that comes in contact with the underside of the barrel’s arrow flight groove).

2. **Attach the bow assembly to the stock assembly as follows:**

- Position the bowstring on top of the barrel’s flight deck while you insert the cable saver (concave side up) and the cables into the barrel’s cable slot. The cable saver’s concave groove (“dish”) should mate with the underside of the barrel’s arrow flight groove (photo 3).

- Ensure that the pre-installed VIBRA-CUSH™ is in place with its cutout side facing the barrel (photo 4).

- Pull the bow assembly toward the trigger assembly until the riser location rod, protruding from the front of the barrel and through the VIBRA-CUSH™, mates with the hole in the riser. Do not twist or rock the bow assembly to the extent that you rub the cables along the slightly sharp edges of the barrel’s cable slot. You do not want to cut any of your cable strands. Pulling up and back slightly on the bowstring may assist you in seating the bow assembly onto the stock assembly (photo 5).

- After you make sure the main assembly bolt’s locking setscrew is loosened, insert the main assembly bolt. You may need to use your free hand to lift the string off the barrel (sometimes as much as an inch) until the hole in the end of the riser rod and the assembly bolt hole in the riser are perfectly aligned. Then, finger-tighten the bolt at least a few turns.

- Finish tightening the bolt using your Allen wrench while continuing to lift the string off the barrel (photo 6). If the alignment is correct, you will have no difficulty. Do not use a cheater-bar when tightening the main assembly bolt.

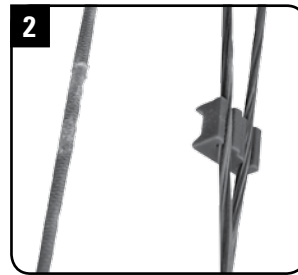

2 Make certain your cables go into the correct slots in your cable saver.

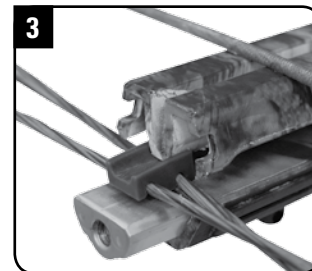

3 The bow string sits on the barrel's flight deck while the cable saver and cables slide into the cable slot.

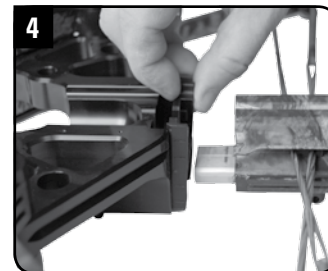

4 The VIBRA-CUSH™ goes between the riser and the barrel, cutout side facing the barrel.

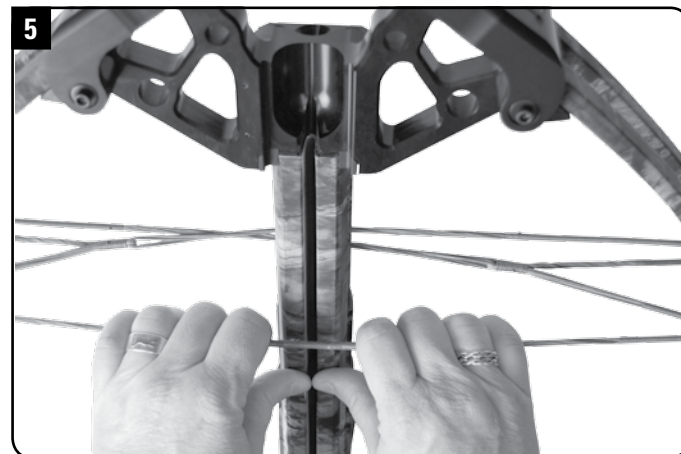

5 Pull up and back slightly on the bow string to seat the bow assembly.

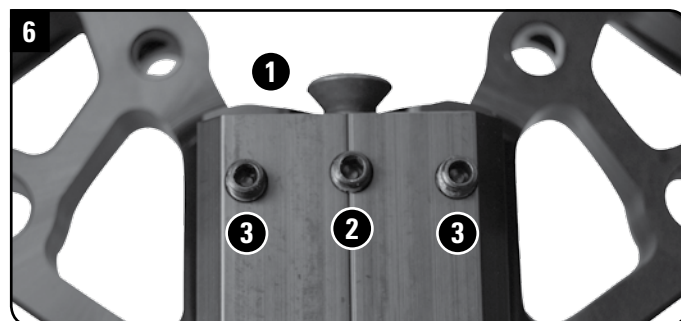

1. Main Assembly Bolt
2. Main Assembly Bolt's Locking Setscrew
3. Foot Stirrup Locking Setscrew

ASSEMBLY STEPS (Cont.)

- Insert the foot stirrup into the two receiving holes located at the front of the riser. Make sure the “valley” in the stirrup’s foot-pad points down so that it does not block the arrow’s flight path. Tighten the locking setscrews located on the bottom of the riser to lock the main assembly bolt and the foot stirrup in place (photo 7).

Note: If you will be mounting the HX Instant Detach Quiver, follow the directions in the Quiver Mounting section below.

- You are now ready to test-fire your crossbow and fine-tune your sights (**See appropriate Cocking, Loading & Sighting sections in the general manual.**)

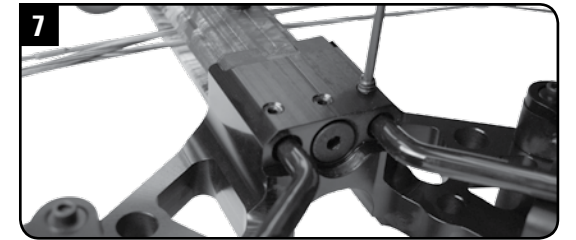

7 Once the foot stirrup is in place, tighten all three setscrews. See below if mounting the HX Instant Detach Quiver.

STEALTH XLT QUIVER MOUNTING

Your Stealth XLT quiver mounting kit is easy to install.

The quiver mounting kit contains the following parts (photo 1):

- Quick disconnect (female) attachment with lever (1)
 - Phillips pan-head machine screws (2)
 - Quiver mounting bracket (1)
 - 7/16-inch Nylock Nuts (2)*
 - 3/4-inch setscrews (2)*
 - HX Instant Detach Quiver with quick disconnect (male) attachment (1)
- *Denotes parts pre-assembled at the factory

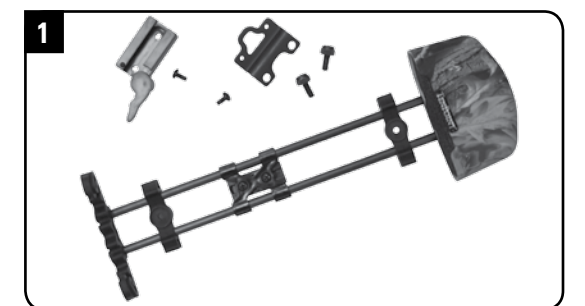

TenPoint Series Quiver Mounting Kit

1. Attach the quick disconnect (female) attachment to the quiver mounting bracket using the two Phillips pan-head machine screws provided.

2. Completely remove the two 1/4-inch setscrews from the bottom of the riser (photo 2).

3. With the foot stirrup in the proper position, place the quiver bracket assembly over the two holes from which you just removed the 1/4-inch setscrews. The mounting bracket holes should face forward toward the foot stirrup. Insert the two 3/4-inch setscrews (with Nylock nuts) into the same holes and tighten (photo 3).

4. Tighten the two Nylock nuts on the setscrews until the quiver mounting bracket is secure. Use a 7/16-inch open-ended wrench to tighten (photo 4).

Note: Do not over-tighten.

5. Insert the HX Instant Detach Quiver, with male attachment, into the quick disconnect attachment and lock in place with the lever (photo 5).



Quiver Mounted to Bow

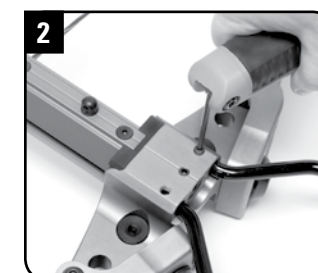

2 Remove 1/4-inch setscrews from the bottom of the riser.

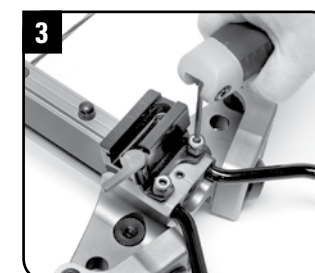

3 Place the quiver bracket assembly over the two setscrew holes and insert 3/4-inch setscrews with Nylock nuts.

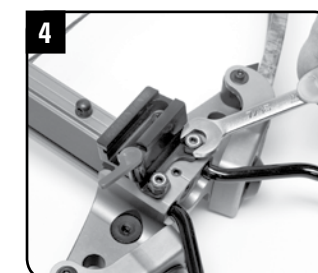

4 Tighten the Nylock nuts with a 7/16-inch open-ended wrench.

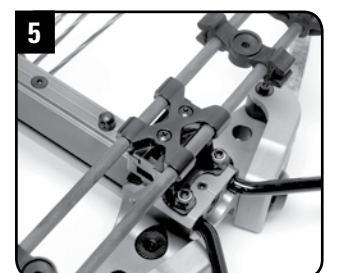

5 Insert the HX Instant Detach Quiver into place and lock in place with the lever.

The GripSafety is a secondary safety button positioned on the side of the crossbow's fore-grip (photo 1). The GripSafety is designed to encourage the shooter to hold the fore-grip properly – and safely – below the surface of the flight rail while shooting the crossbow.

Notice: Due to the technology involved, the GripSafety can only be installed in TenPoint Series models equipped with the PowerTouch Trigger and the machined aluminum ACRA-ANGLE barrel. It is not possible to retrofit TenPoint Series Crossbows equipped with the one-piece composite stock/barrel or any 6 Point Series Crossbows with the GripSafety.



GripSafety button on side of fore-grip.

Operating Instructions

To shoot a GripSafety equipped TenPoint crossbow, shoulder the bow, slide the trigger's brass safety knob forward to the "FIRE" (red dot) position, depress and hold the GripSafety button, and squeeze the trigger. If the trigger safety is engaged ("SAFE" (white dot) position) and/or if the GripSafety is not depressed, you cannot pull the trigger or fire the crossbow.

Right-handed shooters will depress the GripSafety button with the left thumb (photo 2).

Left-handed shooters will depress the GripSafety button with either the index or middle finger (photo 3).

In either case (right or left-handed shooting), the shooter must **still** be careful not to allow any part of the fore-grip hand to work its way above the barrel's flight deck.

Note: Left-handed shooters have the option of having the GripSafety converted so they can depress the GripSafety button with their right thumb. Please contact the Customer Service Department at 330.628.9245 or email your request at www.tenpointcrossbows.com for a Return Authorization Number to return the crossbow for conversion.

Disabling or tampering with the GripSafety will void your Warranty.



Right-handed shooters: Depress the GripSafety with your thumb before squeezing the trigger.



Left-handed shooters: Depress the GripSafety with your middle or index finger before squeezing the trigger.

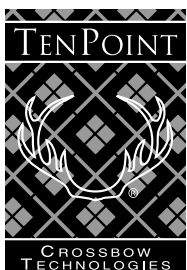

...the mark of perfection™

TenPoint Crossbow Technologies®
1325 Waterloo Road
Mogadore, OH 44260-9608
330.628.9245
www.tenpointcrossbows.com